

ATS Regler (ATC-E, ATC-B)

Technische Daten		ATC-E	ATC-B
Spezifikationen			
Versorgungsspannung DC	V DC	8 - 30 V DC	
Stromverbrauch (max. AC)	VA	4 VA	
Gesteuerte Spannung	V AC	230 V(1F) / 400 V(3F) / 440 V(3F)	
Schaltsteuersignal	-	✓	✗
Bildschirmtyp	-	3 Ziffern, 7 Segmente	
Bemessungstyp	-	RMS	
Bemessungsspannungsbereich	V AC	0 - 500 V AC	
Bemessungsfrequenzbereich	Hz	45 - 65 Hz	
Genauigkeit	%	±2 %	
Betriebstemperatur	°C	-10 / +50 °C	
Lagerungstemperatur	°C	-30 / +70 °C	
Schutzgrad	IP	IP 20	
Max. Leiterquerschnitt	mm <sup>2</sup>	2,5 (Schraubenklemmen)	
Relative Feuchtigkeit	%	95 %	
Gehäusematerial	-	UL94 V0 (Kunststoff)	
Gehäusetyp	-	Standardabmessungen - 96x96	
Abmessungen L x B x H	mm	96 x 96 x 112	
Gewicht	g	230 g	200 g

Schaltpläne

Schaltplan ATC-E

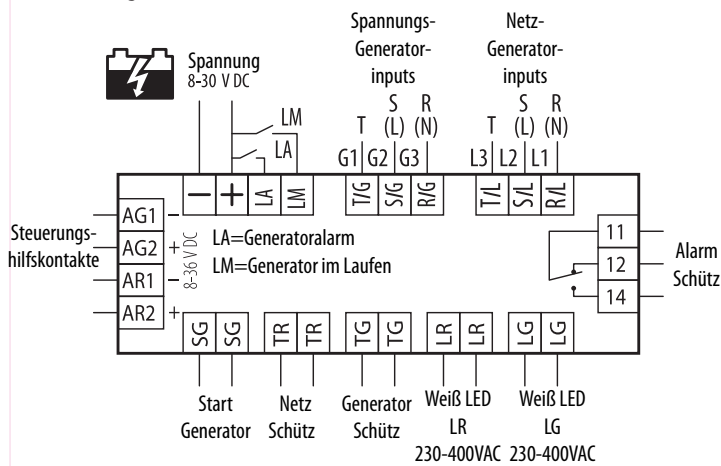

Schaltplan ATC-B

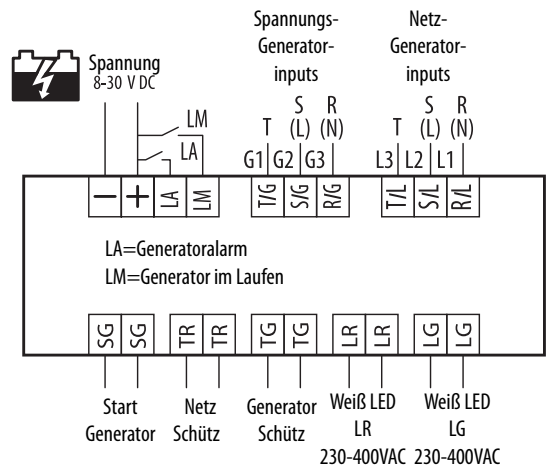

Verbindungsbeispiel

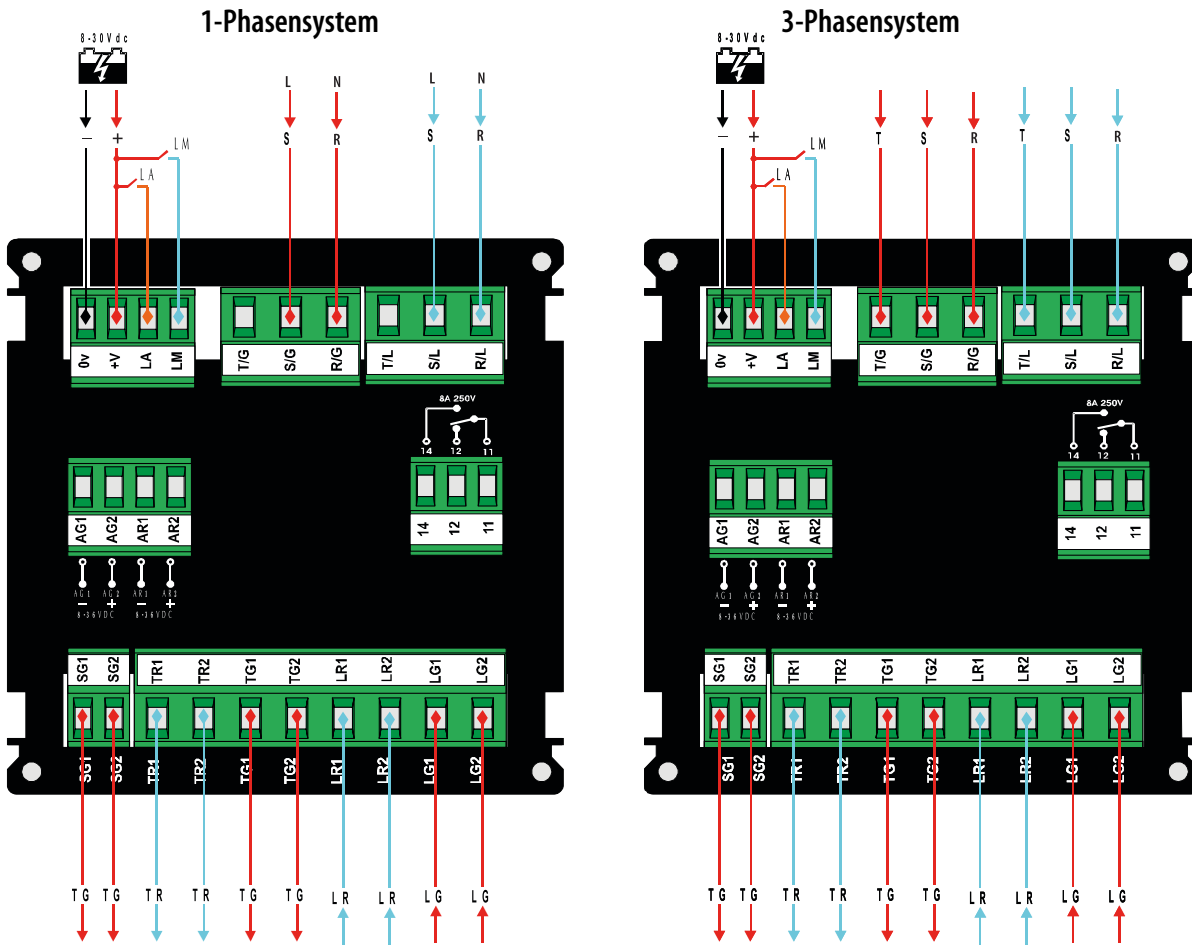

Abmessungen

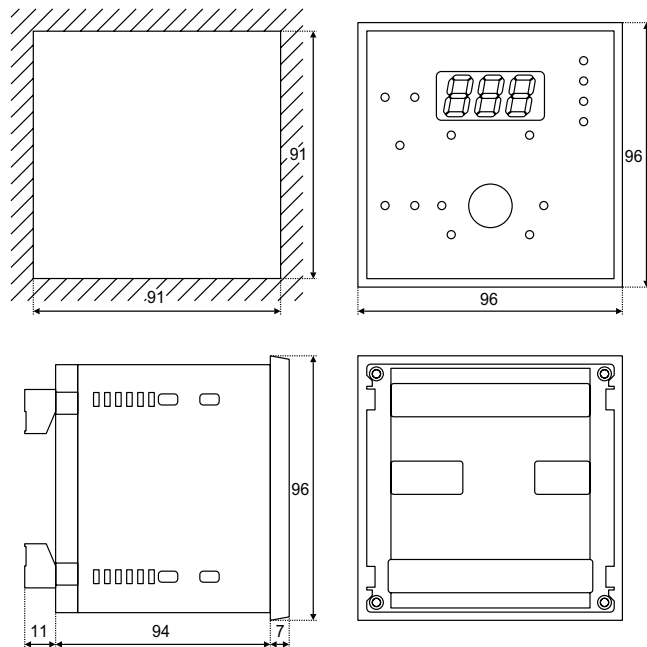

## ATS Regler (ATSC25)

Technical data		ATSC25
Specifications:		ATSC25
Supplied from measurement circuit		184 - 300 VAC
Power consumption		10 W
Measurement range	linear	90 - 520 VAC
	phase	50 - 300 VAC
Frequency		45 - 65 Hz
Emergency input (fire) voltage, V DC		12 - 24 VDC
Communication interface		RS485
Conductor cross section		0,5 - 2,5 mm <sup>2</sup> (screw terminals)
Mounting		DIN rail / door
IP rating		IP 20 (IP40 for front mounting)
Operation temperature		-25 °C ... +60 °C
Operation humidity	80 % / 50 °C	
	95 % / 40 °C	
Dimensions (H × W × D)		96 x 144 x 106
Measurement category		III
Standards		IEC 61010-2-201, IEC 60947-6-1, IEC 60947-1

### Beschreibung

Connectors top view

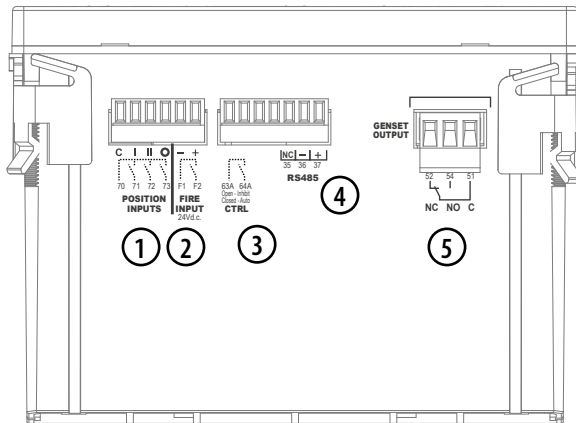

1. RTSE position feedback input
2. 24 V.d.c fire input
3. Enable control when closed / disable control when open
4. RS485 connections
5. Genset Start relay

Connectors bottom view

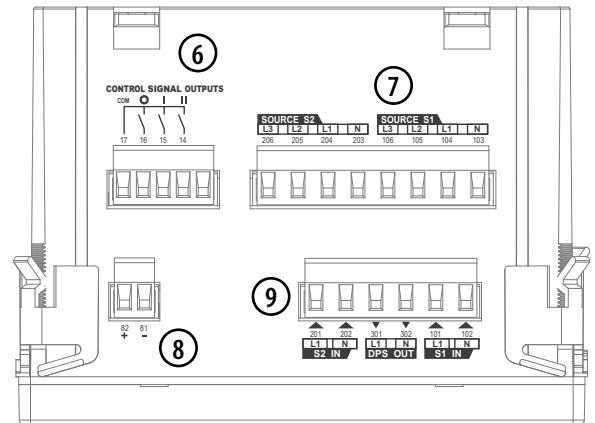

6. RTSE position control outputs
7. Source 1 and 2 voltage inputs
8. 24 V.d.c Aux supply
9. External DPS - Input / output

### Abmessungen

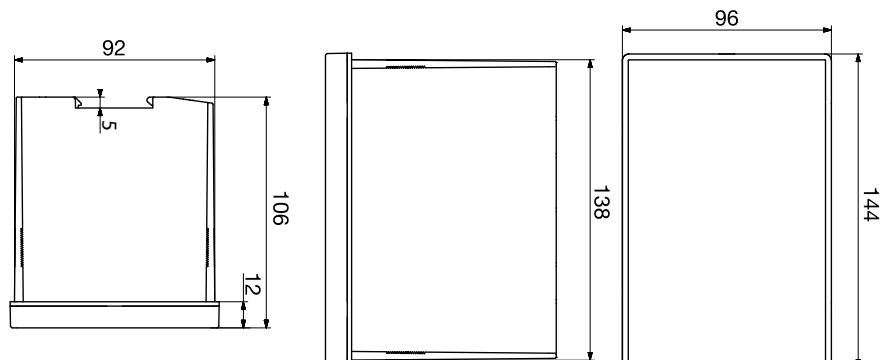

Schaltprogramme

Connection diagrams with MLBS 3P/4P 250...630A

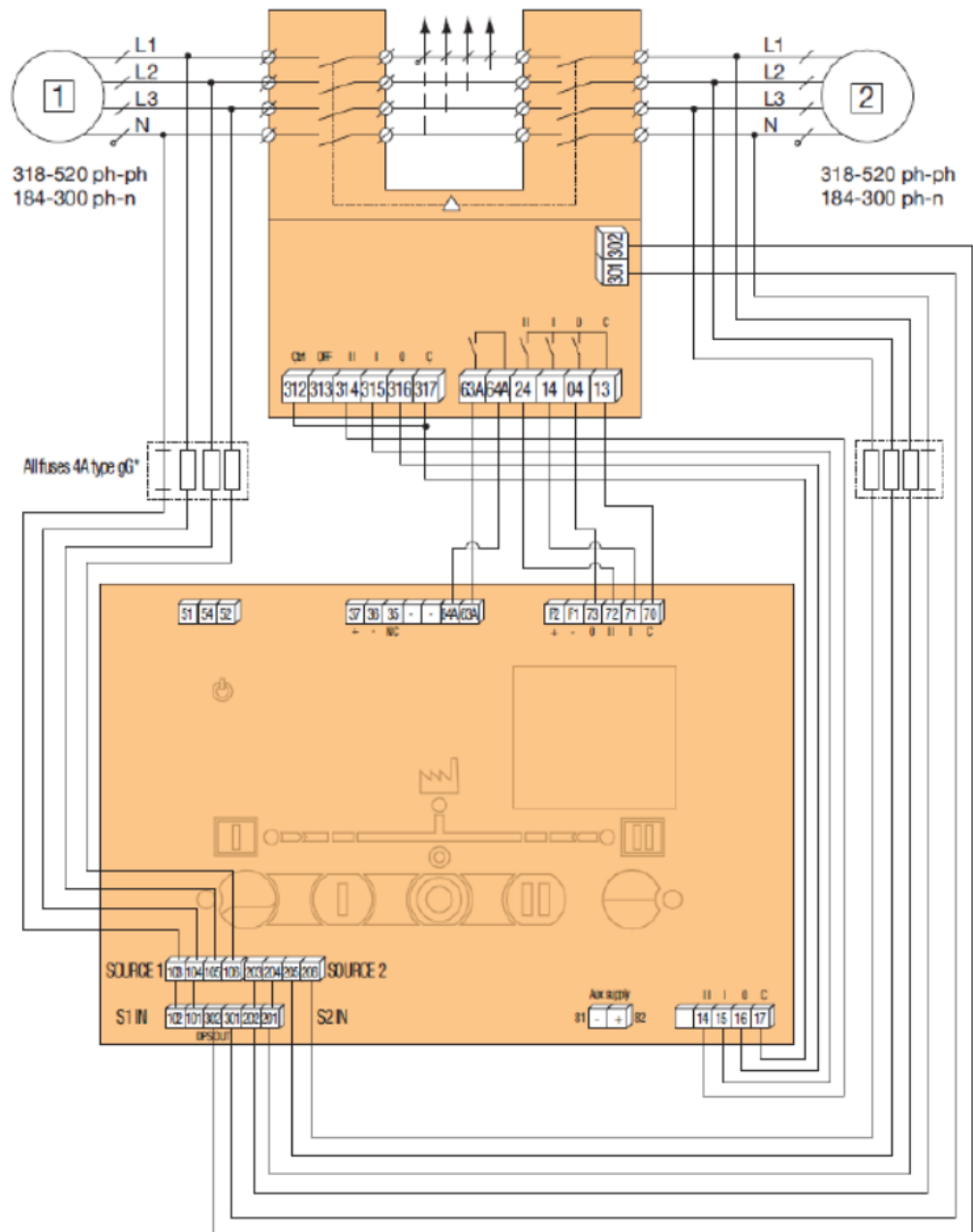

Connections with MLBS 4P 63...125

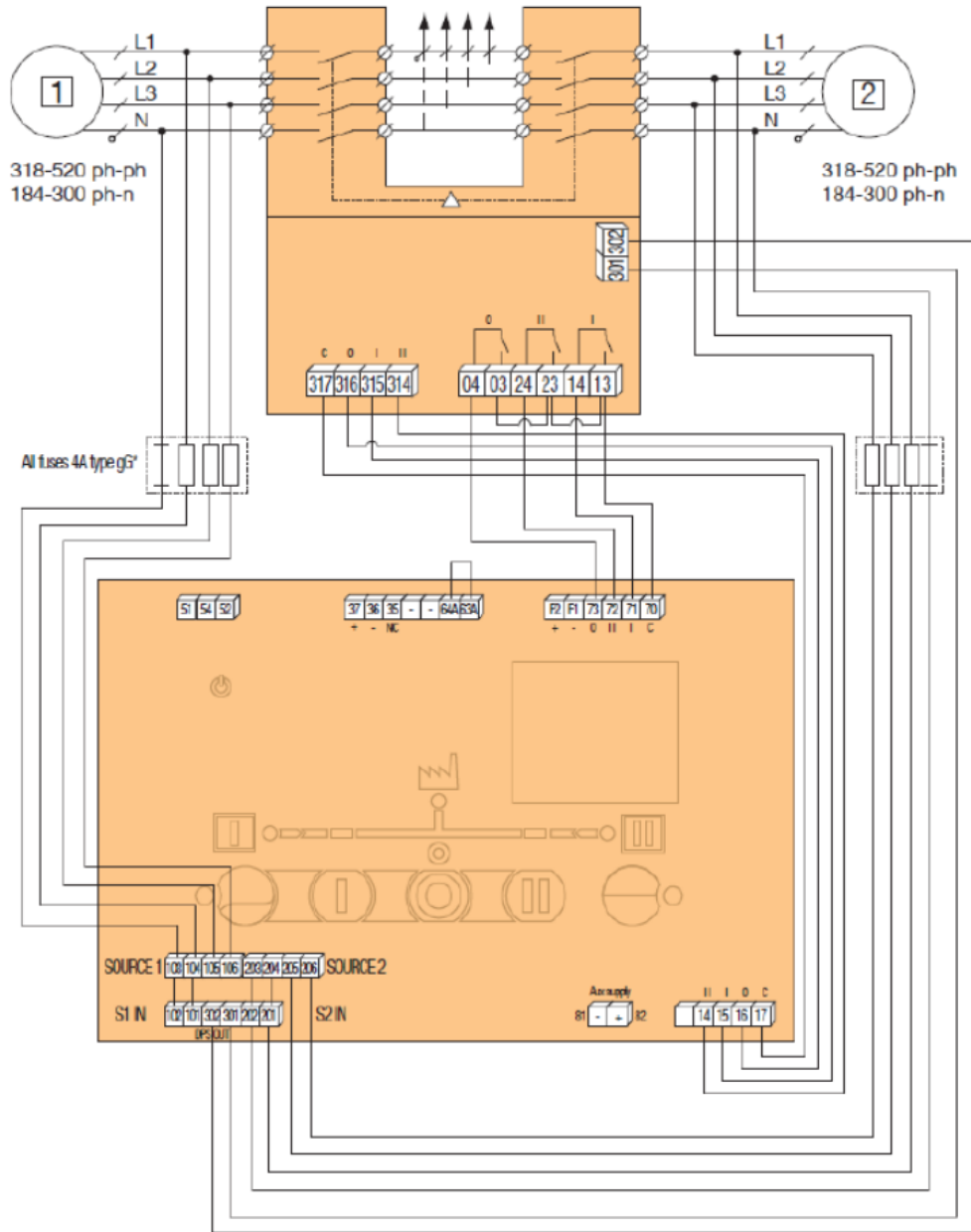

Connections with standard Contactors (CEM and CES)

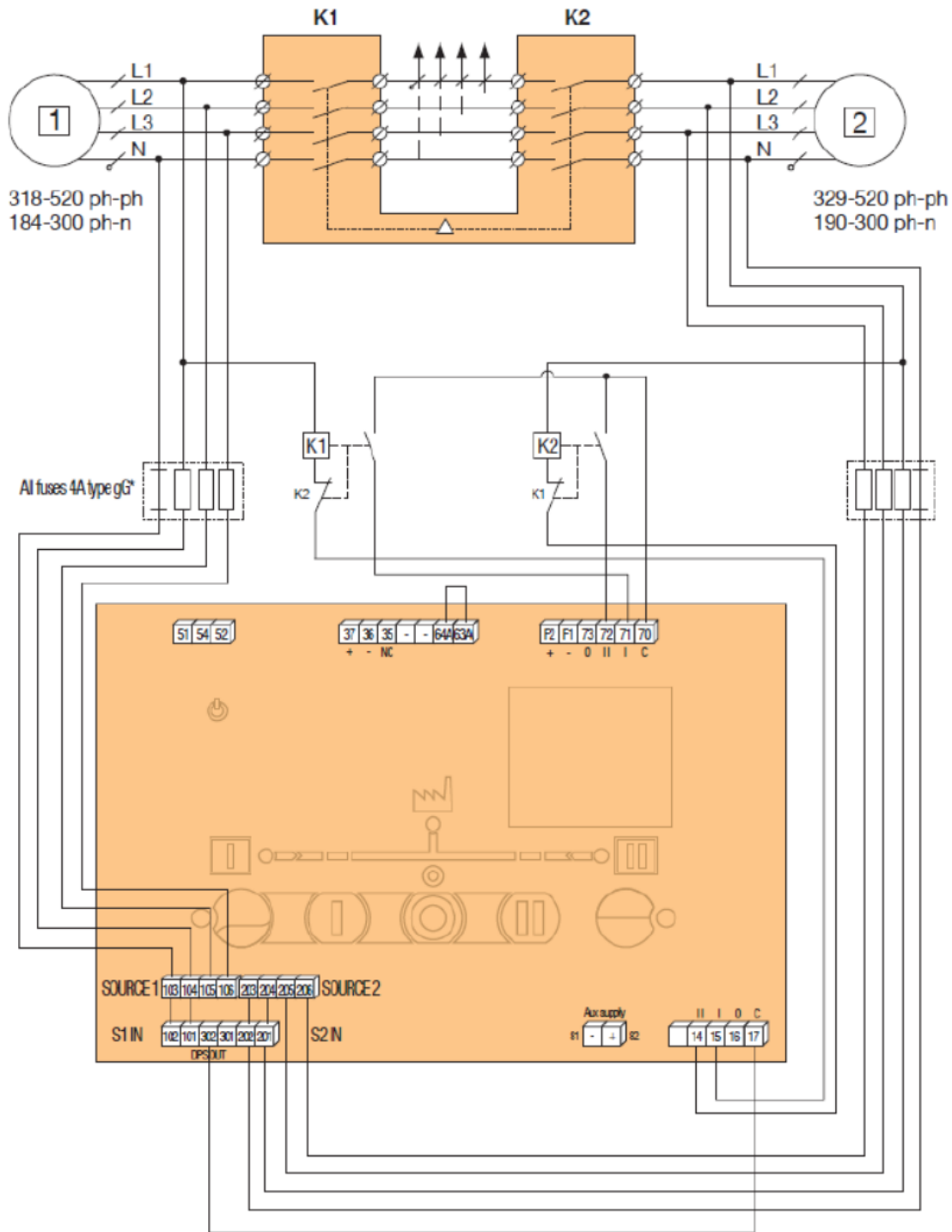



**Mounting**

Door mounting

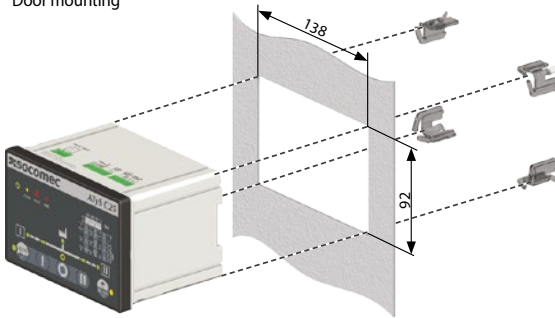

Door cut-out of 93(+0.8) x 138(+1) mm, door thickness 1.5- 3mm.  
Remove all connectors and clip before inserting the controller in the cut-out then fix the controller in place using all 4 fixations clips

DIN rail mounting

1. Mounting



When mounting make sure both clips are pushed up, then clip on the DIN Rail.

2. Unmounting

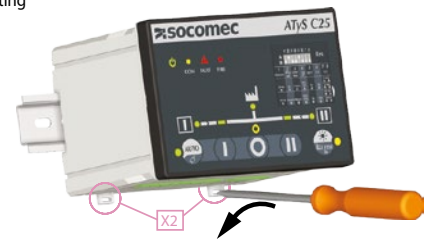

To remove from the DIN Rail, drag the two mounting clips down before removing the product.

**Settings**

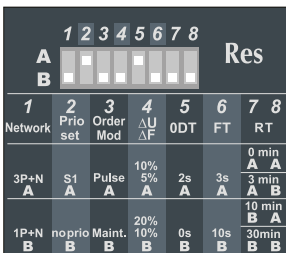

After changing DIP switch settings press RES button shortly (<3s) to validate.

To reset settings configured through communication long press on RES button > 10s.

**DIP Switch**

DIP 1 A/B	A	Three phase network
	B	Single phase network
DIP 2 A/B	A	Priority source 1
	B	No priority
DIP3 A/B	A	Control mode impulse logic
	B	Control mode contactor logic
DIP 4 A/B	A	Overvoltage setting at 10% of nom voltage / overfrequency setting 5% of nominal frequency (hysteresis value is 20% of $\Delta U/\Delta F$ )
	B	Overvoltage setting at 20% of nom voltage / overfrequency setting 10% of nominal frequency (hysteresis value is 20% of $\Delta U/\Delta F$ )
DIP5 A/B	A	Load supply down time of 2 second (ODT = 02 sec)
	B	Load supply down time of 0 second (ODT = 0 sec)
DIP6 A/B	A	Wait time of 3s before source is lost ( Fail timer = 3s)
	B	Wait time of 10s before source is lost ( Fail timer = 10s)
DIP 7 & 8 A/B & A/B	AA	Wait time of 0min before source returns ( retrun timer = 0min)
	AB	Wait time of 3min before source returns ( retrun timer = 3min)
	BA	Wait time of 10min before source returns ( retrun timer = 10min)
	BB	Wait time of 30min before source is lost returns ( retrun timer = 30min)

Denomination	Terminal	Description	Characteristics
Control signal outputs (orders to RTSE)	14	Position II order	AC1 – General use – Ie:5A, Ue: 250V DC – General use – Ie:5A, Ue:30V
	15	Position I order	
	16	Position 0 order	
	17	Common point for position output	
RS485	35	NC – Not connected	RS485 Isolated bus
	36	Negative electrode	
	37	Positive electrode	
Genset output	51	Common point	AC1 – General use – Ie:3A, Ue: 250V DC – General use – Ie:3A, Ue:30V
	52	Normally closed contact	
	54	Normally open contact	
Controller inhibit input	63A	Controller is inhibited when this contact is open	Do not use external voltage - Power from common point
	64A		
	70	Common point for position inputs	
	71	Position I RTSE	
Position inputs (return of information from RTSE)	72	Position II RTSE	Do not use external voltage - Power from common point
	73	Position 0 RTSE	
Fire input	F1	Negative electrode of the 24 Vd.c	11-25 Vd.c
	F2	Positive electrode of the 24 Vd.c	
Optional Aux supply 24Vd.c	81	Negative electrode of the 24 Vd.c	19-30 Vd.c
	82	Positive electrode of the 24 Vd.c	
Source 1 and 2 voltage inputs	103	Source 1 N	Sensing range : 90-520 VAC (ph-n) 50-300 VAC L-N Supply range : 161-300 VAC (ph-n) Max consumption 10 W
	104	Source 1 L1	
	105	Source 1 L2	
	106	Source 1 L3	
	203	Source 2 N	
	204	Source 2 L1	
205	Source 2 L2		
206	Source 2 L3		
DPS output (RTSE power supply)	301	Phase output	AC1 – General use – Ie:8A, Ue: 250V DC – General use – Ie:5A, Ue:30V 150W
	302	Neutral output	