

Cylindrical fuse-link

Technical data	
Rated voltage	400 V AC, 500 V AC, 690 V AC
Rated current	CH 8 1-25 A/400 V
	CH 10 0,5-16 A/500 V, 20-32 A/400 V
	CH 14 2-25 A/690 V, 32-50 A/500 V
	CH 22 16-40 A/690 V (50 A/690 V aM), 50-100 A/500 V
Rated frequency	50 Hz
Rated breaking capacity	CH 8 50 kA
	CH 10 100 kA
	CH 14 2-25 A/80 kA, 32-50 A/120 kA
	CH 22 16-40 A/80 kA (50 A/80 kA aM), 50-100 A/120 kA
Characteristics	gG, aM
Body material	ceramic
Material of contact parts	CuZn28, gal.Ag

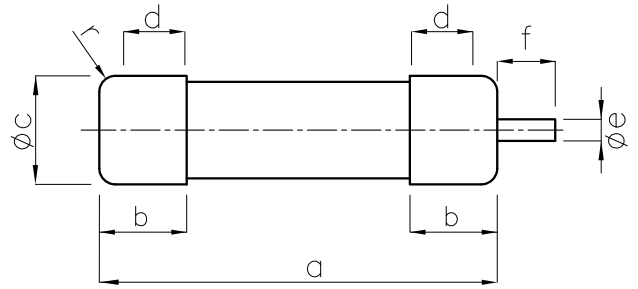

With striker pin

size	e	f
14 x 51	3,8	7,5
22 x 58	3,8	7,5

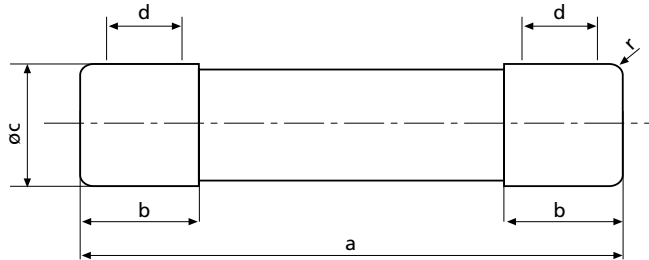

size	a	b _{max}	c	d _{min}	r
8 x 32	31,5±0,5	6,7	8,5±0,1	4	1±0,5
10 x 38	38,0±0,6	10,5	10,3±0,1	6	1,5±0,5
14 x 51	51,0+0,6/-1	13,8	14,3±0,1	7,5	±1
22 x 58	58,0+0,1	16,2	22,2±0,1	11	±1

Time current characteristics
I/t, gG
CH8

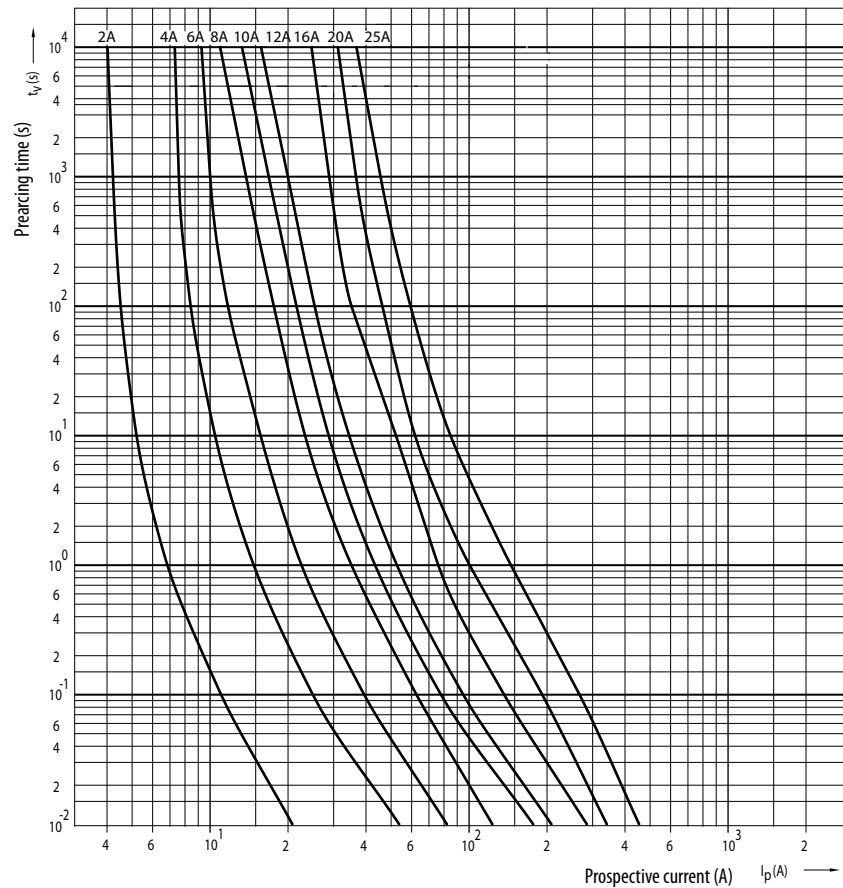

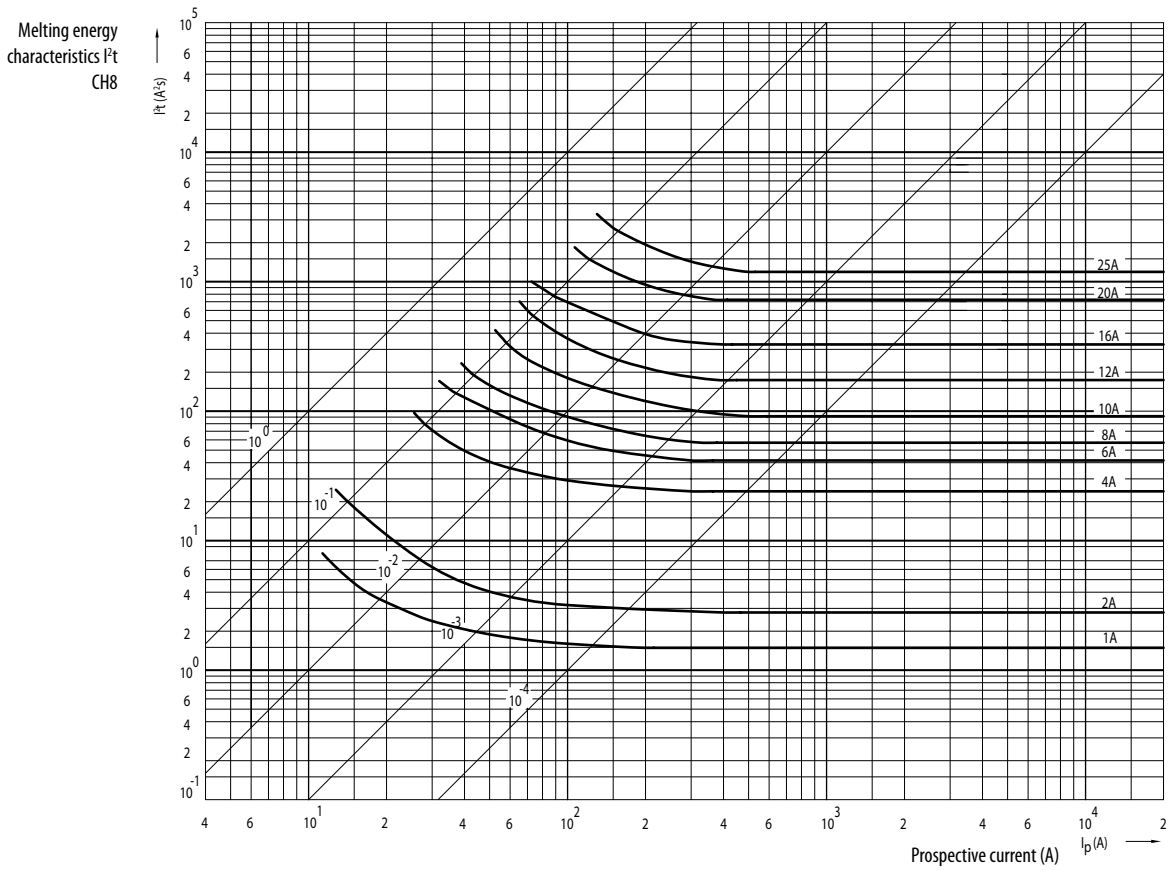
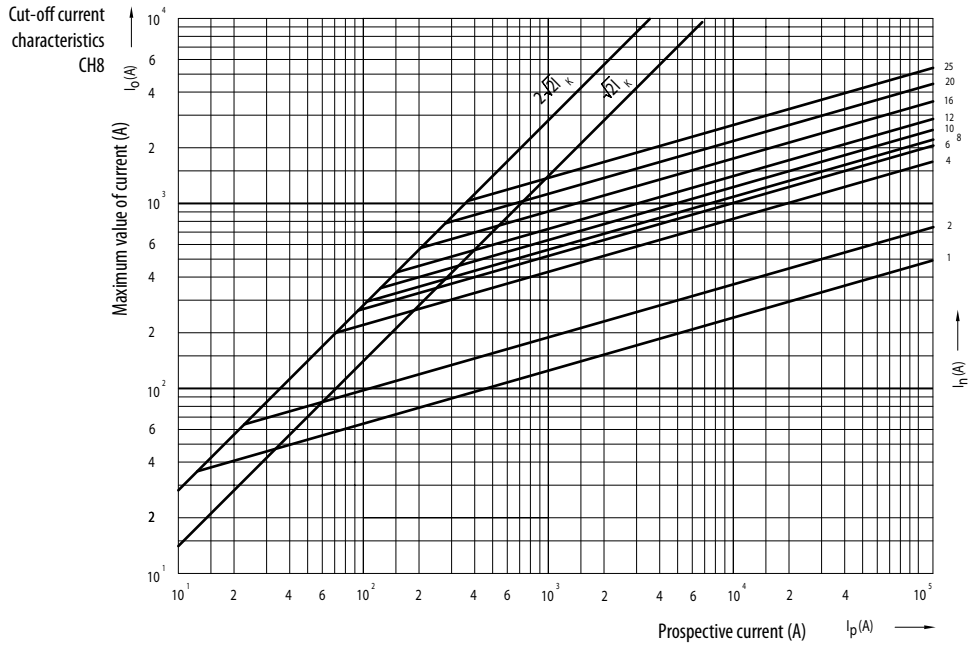

Technical data

Time current characteristics
I/t, gG
CH10

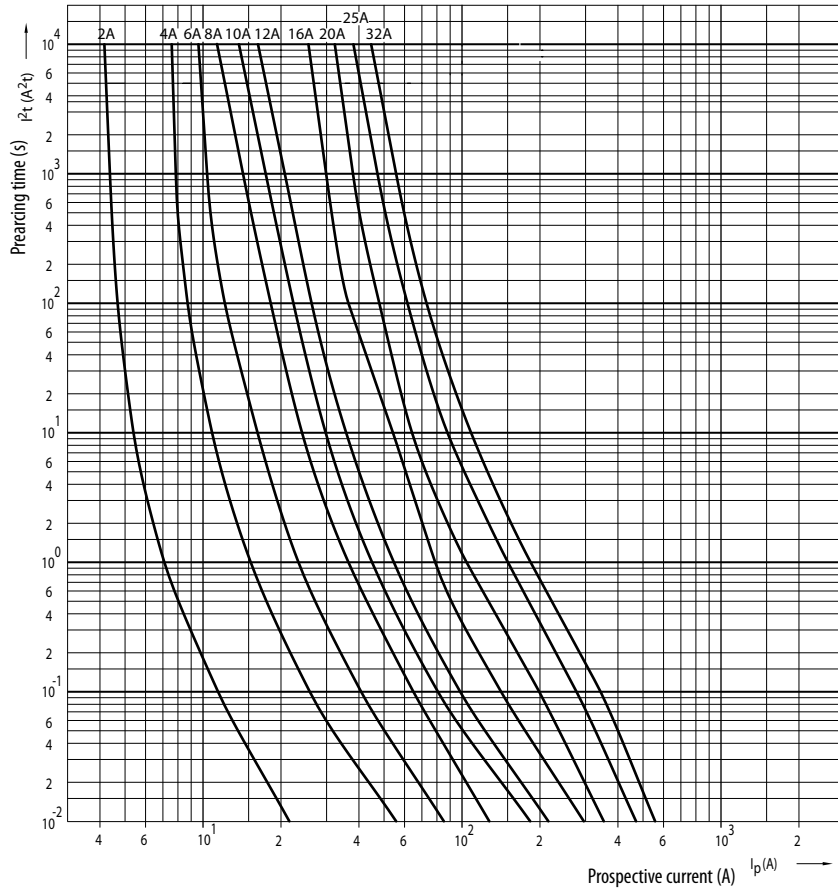

Cut-off current characteristics
CH10

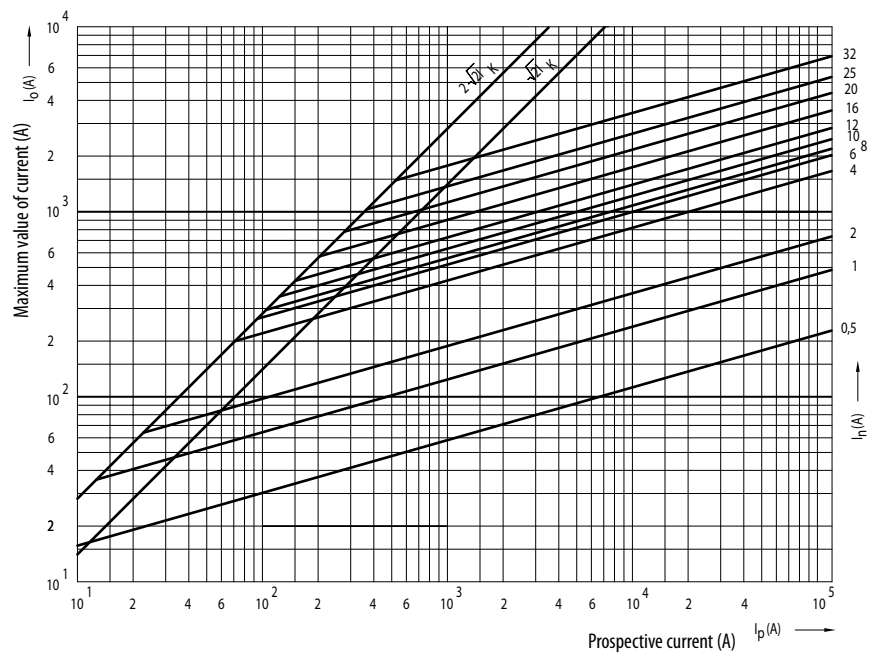

Melting energy characteristics I²t CH10

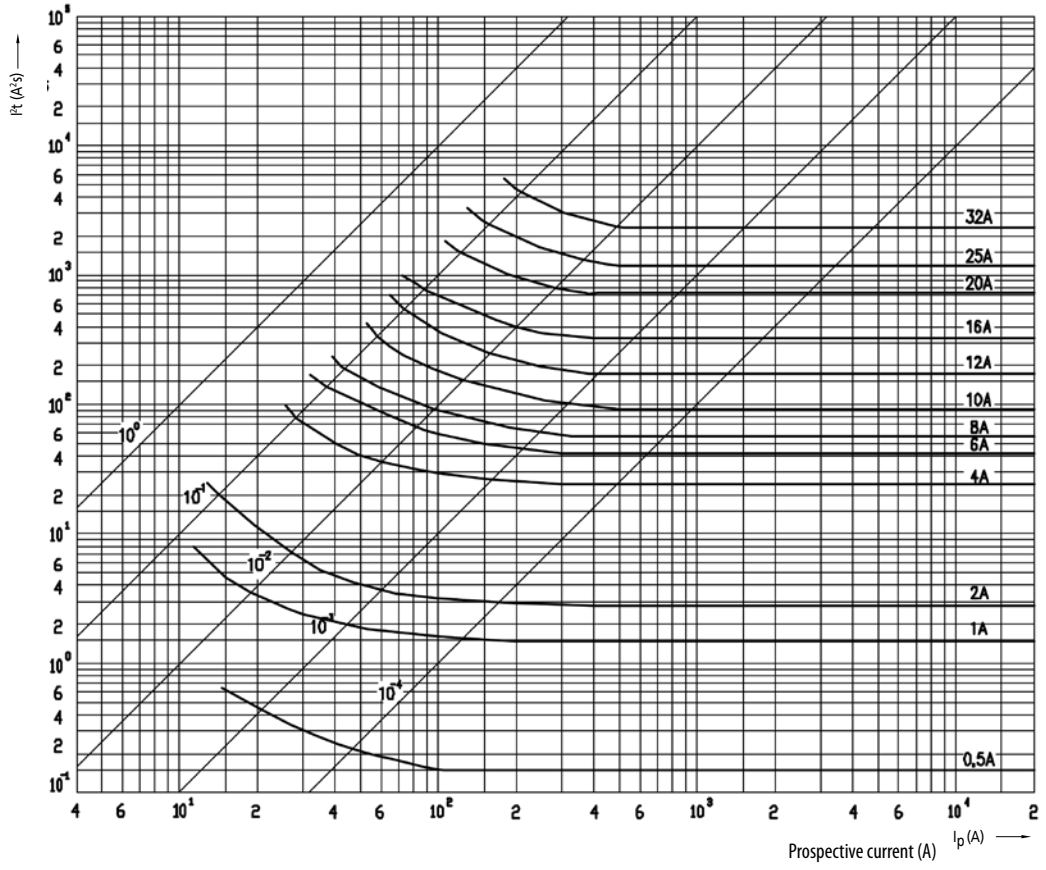

Time current characteristics I/t, gG CH14

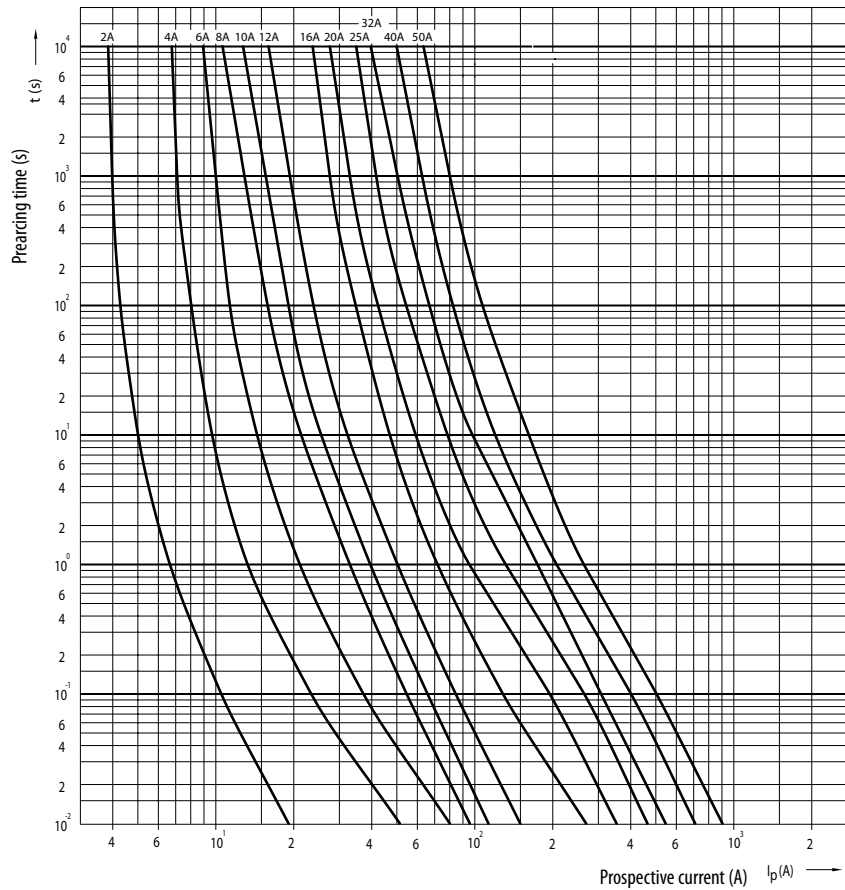

Technical data

Cut-off current characteristics
CH14

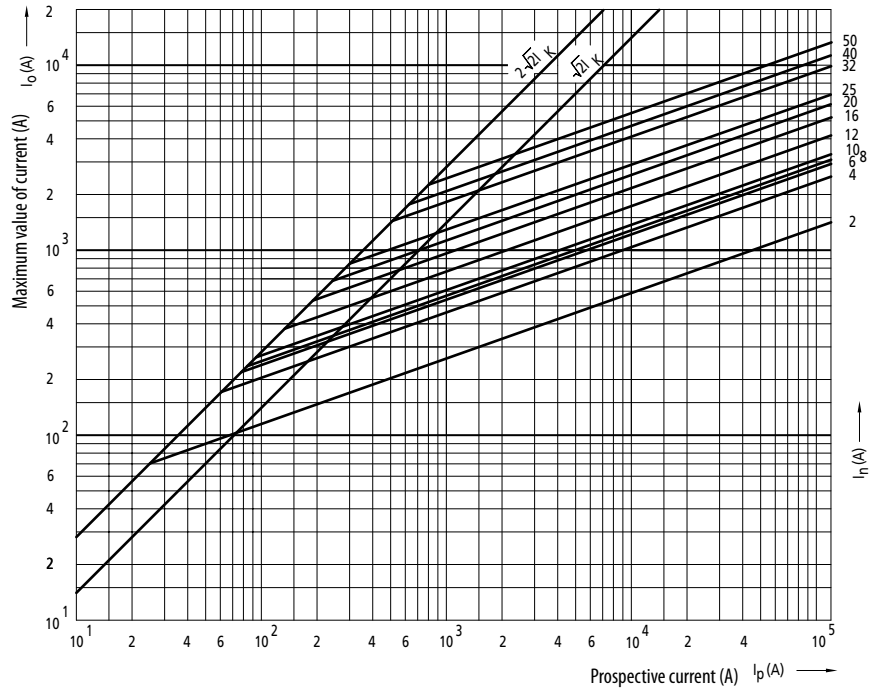

Melting energy characteristics I^2t
CH14

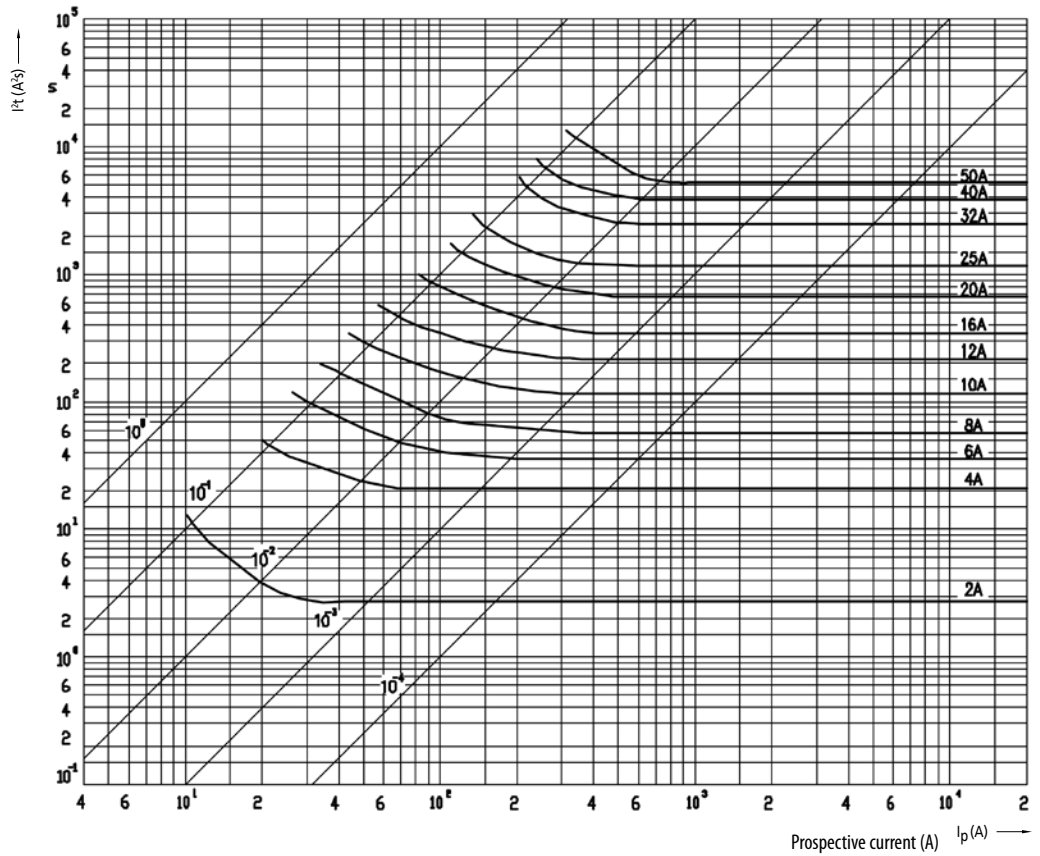

Time current characteristics
I/t, gG
CH22

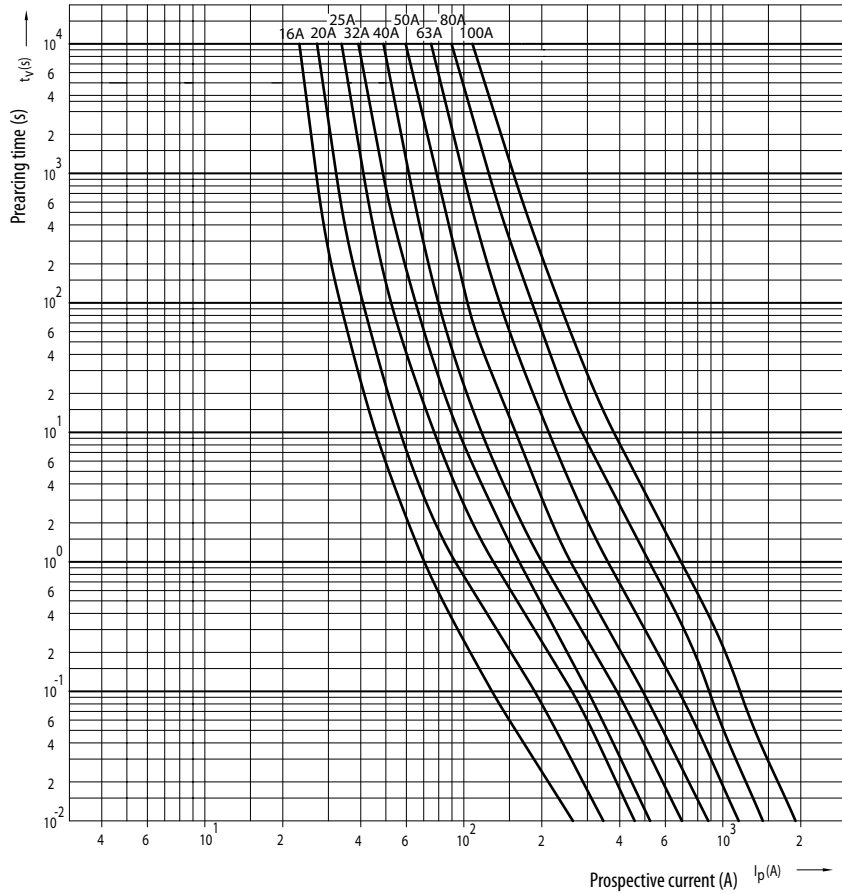

Cut-off current characteristics
CH22

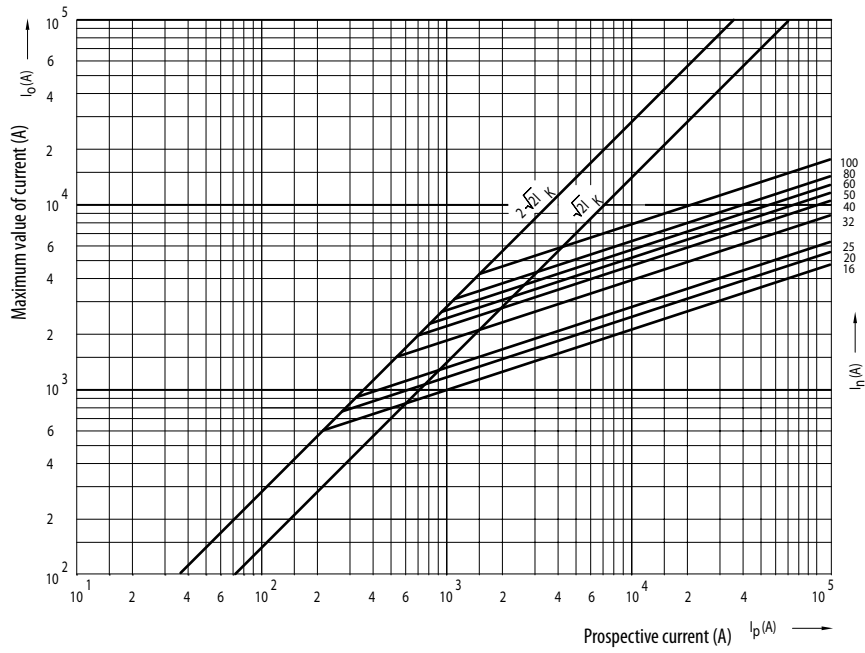

Technical data

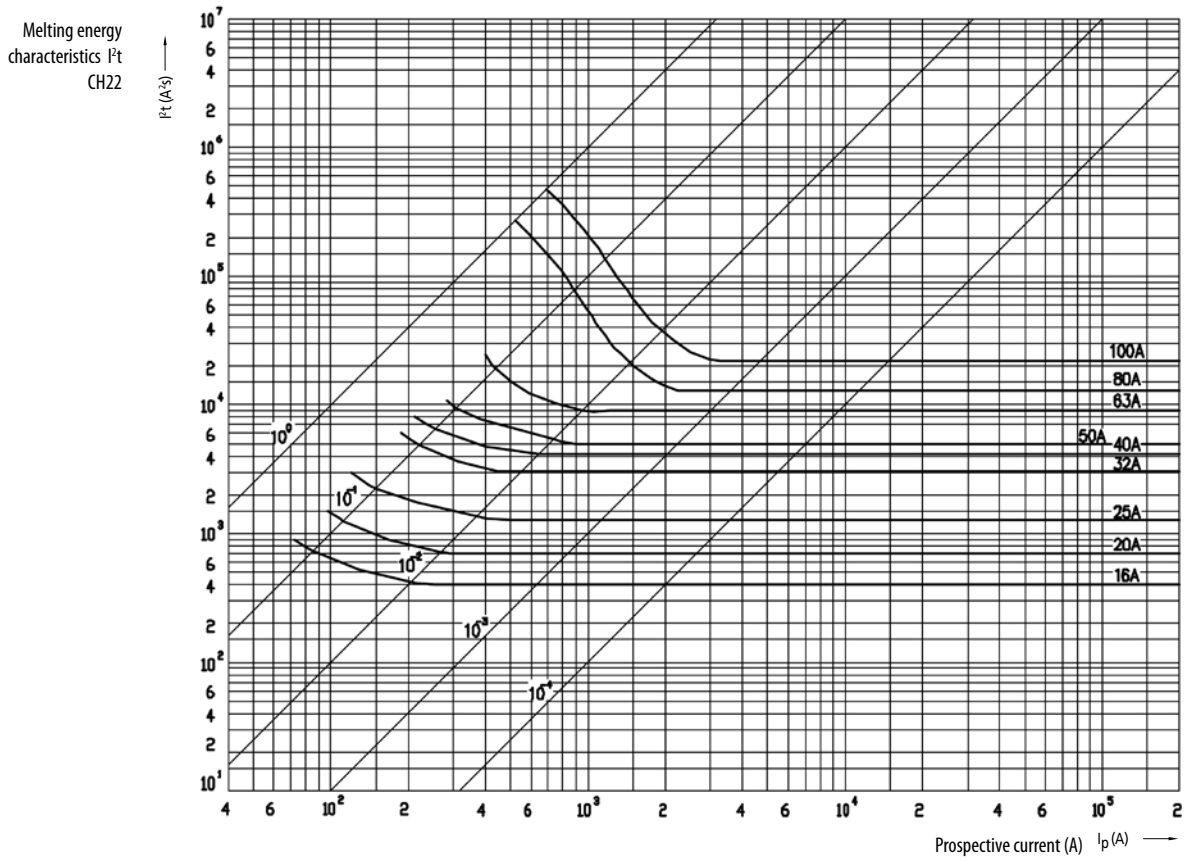

Time current characteristics
 $I/t, aM$
CH10, 14, 22

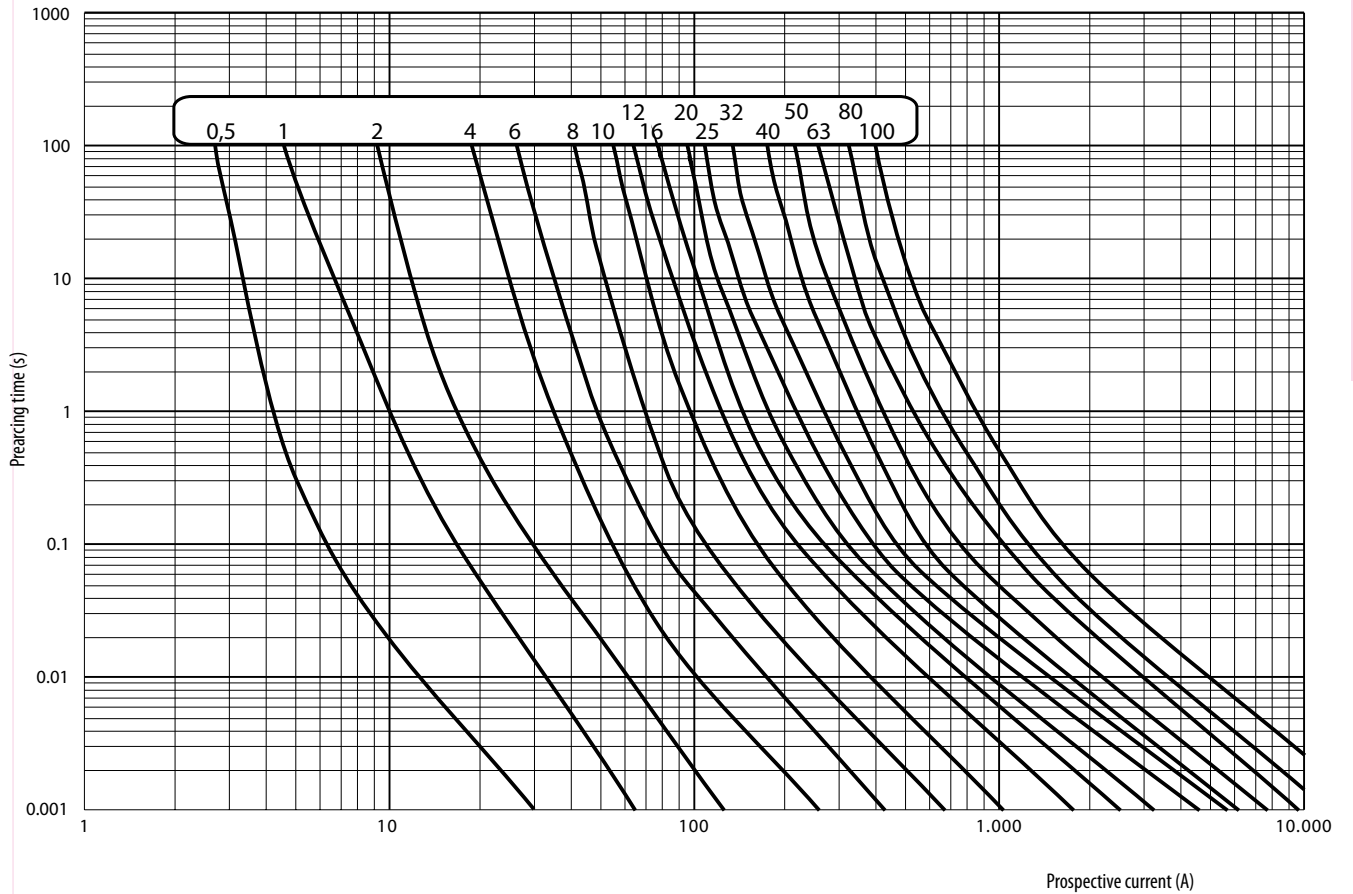

Fuse-switch disconnectors for cylindrical fuse-links EFD

Technical data EFD											
	EFD 8		EFD 10		EFD CC		EFD 14		EFD 22		EFD J30
Fuse type	CH 8x32		CH 10x38		Class CC		CH 14x51		CH 22x58		Class J, size J30
	IEC		IEC		UL		UL		IEC		UL
Versions	Without indicator/LED indicator/NEON indicator		Without indicator / LED indicator								
Number of poles	1p, 1p+N, 2p, 3p, 3p+N		1p, 2p, 3p		1p, 1p+N, 2p, 3p, 3p+N		1p, 2p, 3p		1p, 1p+N, 2p, 3p, 3p+N		1p, 2p, 3p
Rated operational voltage Ue	400V a.c.		690V a.c.		600V a.c./d.c.		600V a.c./d.c.		690V a.c.		600V a.c./d.c.
Rated operational current Ie	20A		32A		30A		30A		50A		50A
Maximum rated current of fuselinks	690V		10A gG						25A gG 25A aM		50A gG 50A aM
	500V		25A gG 16A aM						50A gG		100A gG
	400V		20A gG 10A aM		32A gG		50A aM		100A aM		
Rated frequency	50Hz		50Hz		60Hz		60Hz		50Hz		60Hz
Rated short-time withstand current Icw	240A		300A/1s				600A/1s		1200A/1s		
Conventional free air thermal current Ith							50A		100A		
Rated conditional short-circuit current	50kA		100kA/400V		100kA		200kA		gG: 120kA/500V (50A gG) aM: 50kA/400V (50A aM)		100kA
Rated insulation voltage Ui	400V		690V				690V		690V		
Rated imp. withstand voltage Uimp	8kV		8kV				8kV		8kV		
Overtoltage category (according to Table H.1 in IEC 60947-1 and according to IEC 60099-1)	III		III				III		III		
Max power dissipation of the fuse-link (W)	gG: 2,5W aM: 0,9W		gG: 3W aM: 1,2W		3W		gG: 5W aM: 3W		gG: 9,5W aM: 7W		6W
LED indicator operating range	50V-690V a.c.		50V - 600V a.c. 80V - 600V d.c.		50V-690V a.c.		50V - 600V a.c. 80V - 600V d.c.		50V-690V a.c.		50V - 600V a.c. 80V - 600V d.c.
NEON indicator operating range	100V-750V a.c.		100V-750V a.c.								
Utilization category	AC-22B		AC-22B		Do not operate under load		AC-22B at 690V/50A		Do not operate under load		AC-21B at 690V/100A
Operational performance (cycles with current)	300		300				300		300		
Operational performance (cycles without current)	1700		1700				1700		1700		
Humidity											
Operating ambient temperature	-5°C ... +40°C						-5°C ... +40°C		-5°C ... +40°C		
Store ambient temperature	-25°C ... +55°C						-25°C ... +55°C		-25°C ... +55°C		
Degree of protection (IEC 60529)	IP 20		IP 20				IP 20		IP 20		
Terminal capacity	1-25mm ²		1-25mm ²		AWG 18-8 solid&stranded Cu only		1,5-35mm ² rigid or flexible		AWG 16-6 solid&stranded Cu only		4-50mm ² rigid or flexible
Screw	PZ M5		PZ M5		PZ M5		PZ M5		PZ M5		PZ M6
Torque	2Nm		2Nm		2Nm; 17,7 lb-in		2,5-3Nm		2Nm; 17,7 lb-in		3Nm
Mounting on EN 60715 rail							35mm rail				
Sealing possibility							ON and OFF				
Standards - fuse links	IEC/EN 60269-2		IEC/EN 60269-2		IEC/EN 60269-2		UL 248-4 IEC/EN 60269-2		IEC/EN 60269-2		IEC/EN 60269-2
Standards - Fuse-switch disconnectors/fuse holders	IEC 60947-1 IEC 60947-3		UL 4248-1 UL 4248-4 UL 486E		IEC 60947-1 IEC 60947-3		UL 4248-1 UL 486E		IEC 60947-1 IEC 60947-3		UL 4248-1 UL 486E
Test reports	CCA/CB		CCA/CB		UL		UL		CCA/CB		UL
Certificates			UR _{US}		UL _{US}				UR _{US}		UL _{US}

Technical data

Technical data EFD

	EFD 8	EFD 10		EFD CC	EFD 14		EFD 22		EFD J30
Fuse type	CH 8x32	CH 10x38		Class CC	CH 14x51		CH 22x58		Class J, size J30
	IEC	IEC	UL	UL	IEC	UL	IEC	UL	UL
Derating factor of current I_n for different ambient temperatures	20°				1				
	30°				0,95				
	40°				0,9				
	50°				0,8				
	60°				0,7				
	70°				0,5				
Derating factor of current I_n for side by side mounting fuse holders (nr. of poles)	1-4				1				
	5-6				0,8				
	7-9				0,7				
	≥10				0,6				

Fuse-switch disconnecter EFD 8, EFD 10

type	dimension B
EFD 8, 10 1p	17,5
EFD 8, 10 1p+N	35
EFD 8, 10 2p	35
EFD 8, 10 3p	52,5
EFD 8, 10 3p+N	70

Fuse-switch disconnecter EFD CC

type	dimension B
EFD CC 1p	17,5
EFD CC 2p	35
EFD CC 3p	52,5

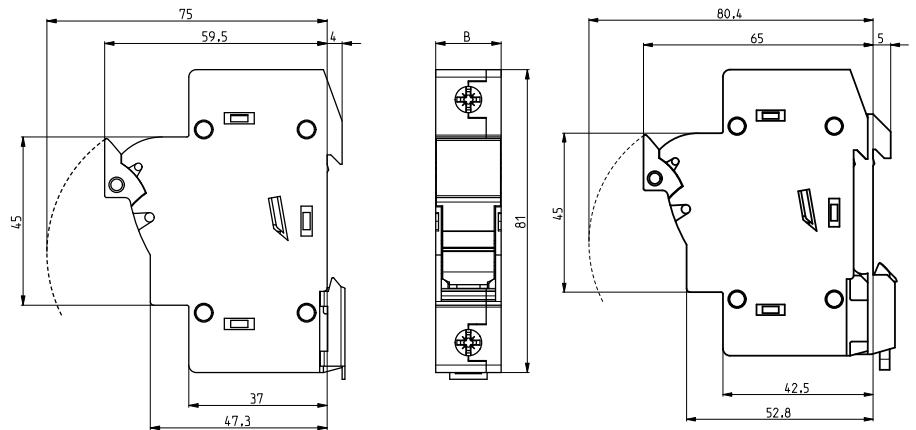

Version with adapter

Fuse-switch disconnecter EFD 14

type	dimension B
EFD 14 1p	27
EFD 14 1p+N	54
EFD 14 2p	54
EFD 14 3p	81
EFD 14 3p+N	108

Fuse-switch disconnecter EFD 22 & EFD J30

type	dimension B
EFD 22, J30 1p	35,6
EFD 22 1p+N	71,2
EFD 22, J30 2p	71,2
EFD 22, J30 3p	106,8
EFD 22 3p+N	142,4

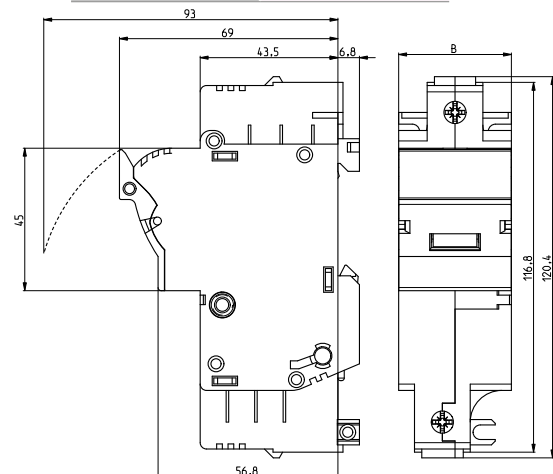
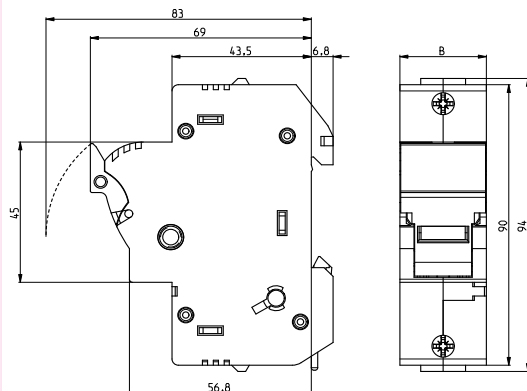

Auxiliary switch EFD

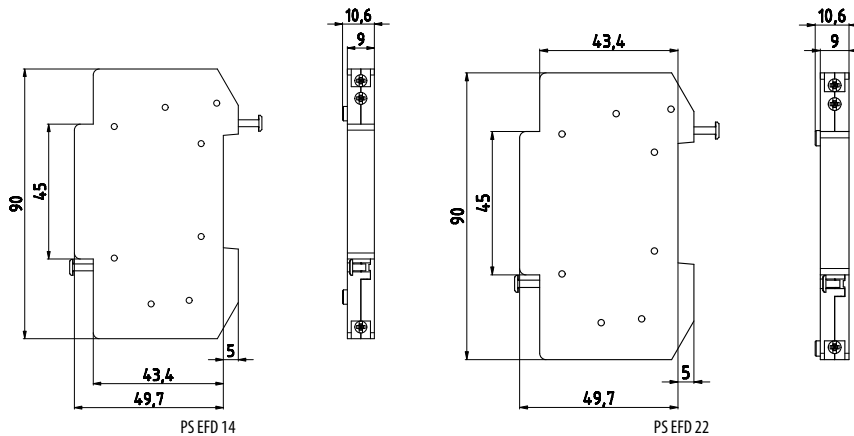

Fuse-switch disconnectors for cylindrical fuse-links PCF

Technical data PCF					
	PCF 8		PCF 10		PCF CC
Fuse type	CH 8x32		CH 10x38		Class CC
	IEC		IEC	UL	UL
Versions	Without indicator / LED indicator				
Number of poles	1p, 1p+N, 2p, 3p, 3p+N			1p, 2p, 3p	
Rated operational voltage Ue	400V a.c.		690V a.c.	600V a.c./d.c.	600V a.c./d.c.
Rated operational current Ie	20A		32A	30A	30A
Maximum rated current of fuselinks	690V	10A gG			
	500V	25A gG, 16A aM			
	400V	20A gG, 10A aM	32A gG		
Rated frequency	50Hz		50Hz	60Hz	60Hz
Rated short-time withstand current Icw	240A		300A		
Rated conditional short-circuit current	50kA		100kA	200kA	200kA
Rated insulation voltage Ui	400V		690V		
Rated imp. withstand voltage Uimp	4kV		4kV		
Overvoltage category	III		III		
Max power dissipation of the fuse-link (W)	gG: 2,5W / aM: 0,9W		gG: 3W / aM: 1,2W		
LED indicator operating range	50V-690V a.c.			50V-600V a.c., 80V-600V d.c.	
Utilization category	AC-22B		AC-22B	Do not operate under load	
Operational performance (cycles with current)	300		300		
Operational performance (cycles without current)	1700		1700		
Humidity	90% at 20°C				
Operating ambient temperature	-5°C ... +40°C				
Store ambient temperature	-25°C ... +55°C				
Degree of protection (IEC 60529)	IP 20		IP 20		
Terminal capacity	0,5-10mm ² , Double connection		20-10 stranded, Cu only	20-10 solid&stranded, Cu only	
Screw	PZ M4		PZ M4	PZ M4	PZ M4
Torque	1,2Nm		1,2Nm	1,2Nm	1,2Nm
Mounting on EN 60715 rail	35mm rail				
Sealing possibility	ON and OFF				
Standards - fuse links	IEC/EN 60269-2			UL 248-4, IEC/EN 60269-2	
Standards - Fuse-switch disconnectors/fuse holders	IEC 60947-1, IEC 60947-3		UL 4248-1	UL 4248-1, UL 4248-4	
Test reports	Int.		CCA/CB	UL	Int
Certificates					UL _{US}

Technical data

Technical data PCF					
		PCF 8	PCF 10		PCF CC
Fuse type		CH 8x32	CH 10x38		Class CC
		IEC	IEC	UL	UL
Derating factor of current I_n for different ambient temperatures	20°	1			
	30°	0,95			
	40°	0,9			
	50°	0,8			
	60°	0,7			
	70°	0,5			
Derating factor of current I_n for side by side mounting fuse holders (nr. of poles)	1-4	1			
	5-6	0,8			
	7-9	0,7			
	≥10	0,6			

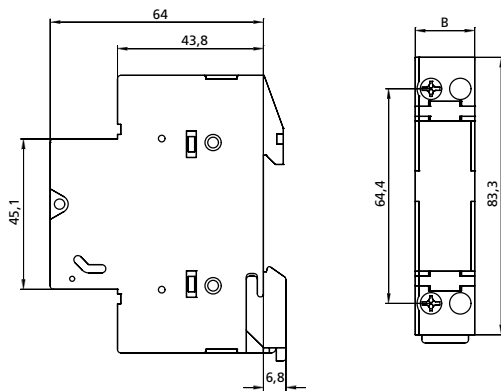

Fuse-switch disconnecter PCF 8, PCF 10, PCF CC

type	dimension B
PCF 8, 10, CC 1p	17,8
PCF 8, 10 1p+N	17,8
PCF 8, 10, CC 2p	35,6
PCF 8, 10, CC 3p	53,4
PCF 8, 10 3p+N	53,4

Auxiliary switch PS PCF

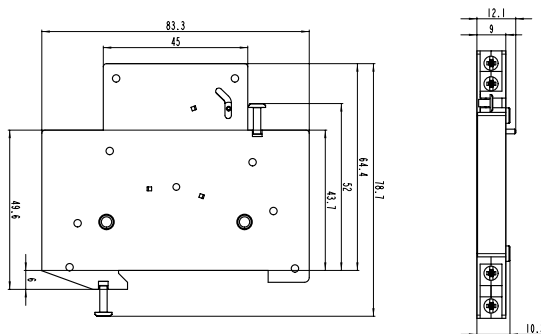

C